

安装说明书

40单槽下水管

记录您的型号

Record your model number : _____ 1506735

English 6

KOHLER®

1520621-T2-A

感谢您选择科勒

需要帮助? 请联系我们的客户服务中心。

- 科勒（中国）投资有限公司
上海市静安区江场三路 158 号 邮编：200436
- 中国大陆：+(86) 800 820 2628, +(86) 400 820 2628
- www.kohler.com.cn

工具和材料

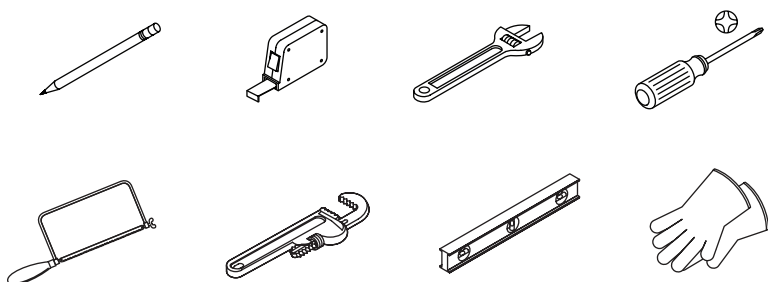

开始之前

- 科勒排水管工作平稳可靠，并保持闪亮的饰面。为了轻松安装，请按照以下分步说明进行操作。
- 在尝试拆除旧排水管或安装新排水管之前，请仔细阅读这些说明。
- 该产品经过精心设计，可使用常用家用工具轻松安装

安装说明

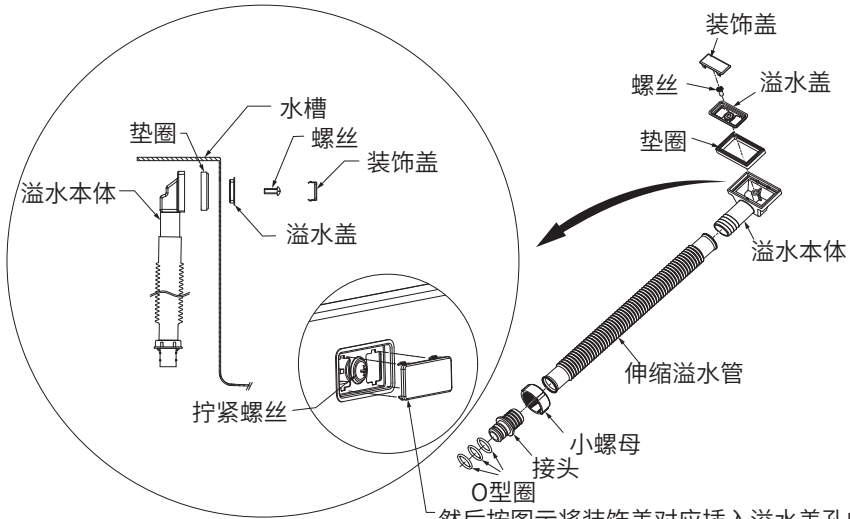

然后按图示将装饰盖对应插入溢水盖孔内并用力按压装饰盖两侧固定。

1. 先将装饰盖、螺丝、溢水盖、垫圈、溢水本体、伸缩溢水管、小螺母、O型圈、接头按图示方式安装到水槽上，拧紧螺丝。

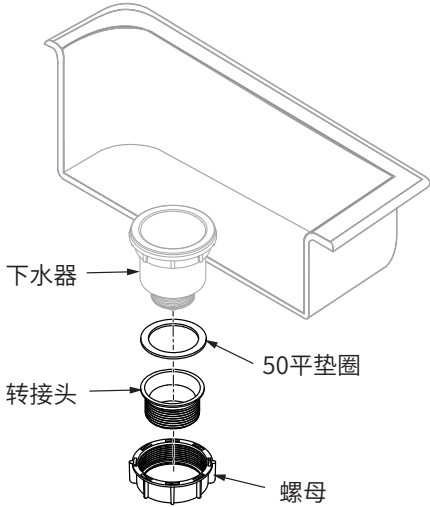

2. 把转接头放入螺母内，把50平垫圈放在转接头和螺母组件上与水槽下水器锁紧。

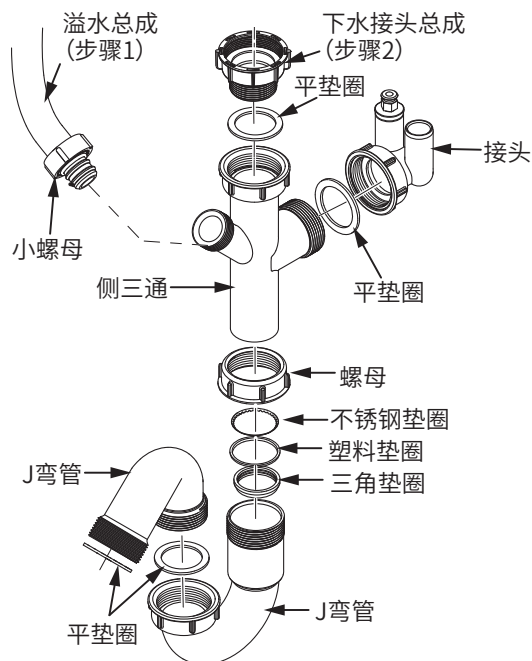

3. 将步骤1中连接的溢水总成通过小螺母连接到侧三通上。通过各处连接的螺母、平垫圈、螺母、不锈钢垫圈、塑料垫圈、三角垫圈连接接头、侧三通和两J型弯管。将步骤3连接的总成通过平垫圈和螺母连接到水槽下水总成上。

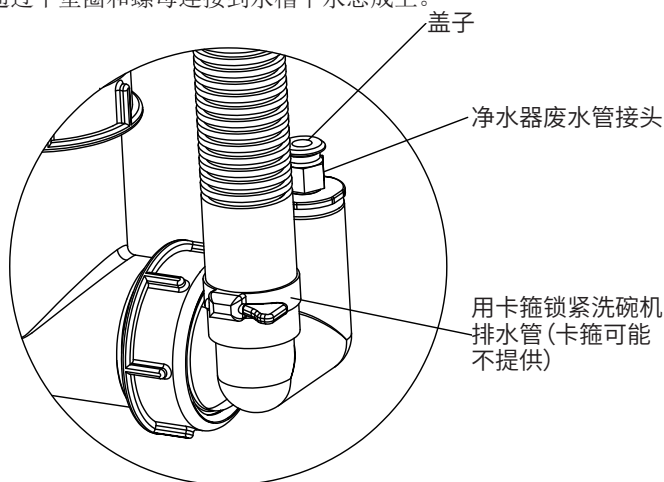

4. 请将洗碗机的排水管连接至洗碗机排水管接头，并用卡箍锁紧排水管（卡箍可能不提供）。如果净水器废水管需要与下水管相连，请拨开净水器废水管接头盖子进行连接。

注意：如无需要，请勿拨开盖子，以免漏水。

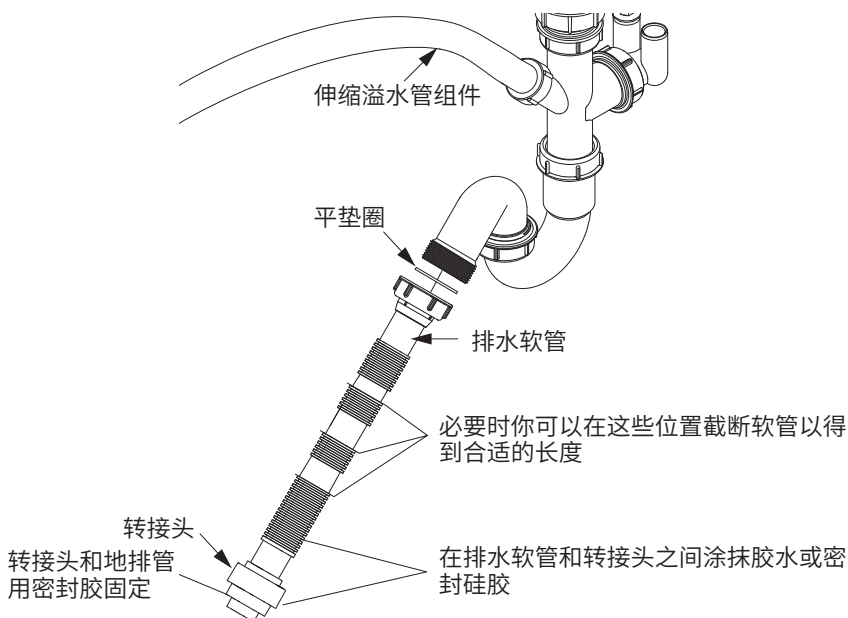

5. 通过平垫圈连接排水软管和J弯管并拧紧螺母。根据水槽与地排口的距离安装排水软管：伸缩溢水管可以通过拉伸或压缩的方式来获得合适的安装长度。

注意：确保各密封垫放置方向正确，按照装配图连接所有管道，先不要完全拧紧，所有管道连接后再拧紧各处螺母。

Installation Instructions

40 S-Trap for Single Basin

Thank You for Choosing KOHLER

Need help? Contact our Customer Care Center.

- Kohler China Investment CO. LTD,
NO. 158, Jiang Chang San Road, Jing'an District,
Shanghai, PRC Post Code: 200436
- Mainland China: +(86) 800 820 2628, +(86) 400 820 2628
- www.kohler.com.cn

Tools and Materials

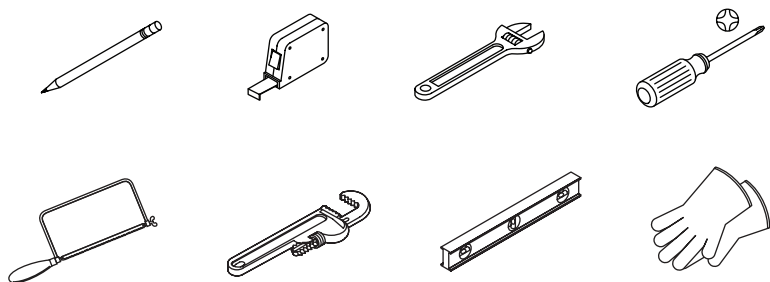

Before You Begin

- Kohler drains work smoothly and reliably, and keep their gleaming finishes. For easy installation, follow these step-by-step instructions.
- Carefully read these instructions before you attempt to remove your old drain or install your new one.
- This product has been designed for easy installation using common household tools.

Installation Instructions

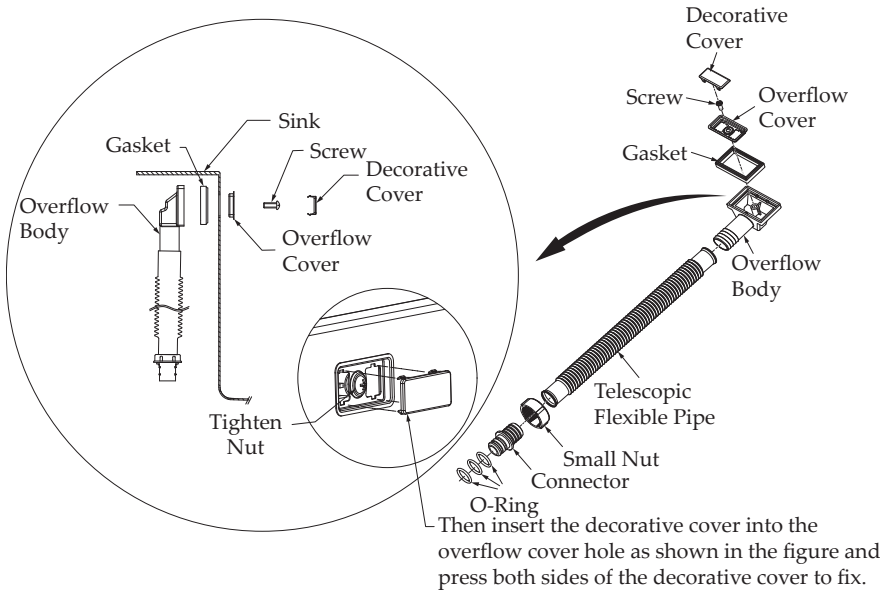

1. Fix the decorative cover, screw, overflow cover, gasket, overflow body, telescopic flexible pipe, small nut, O-ring, and connector to the basin as shown in the picture. Insert and tighten the screw.

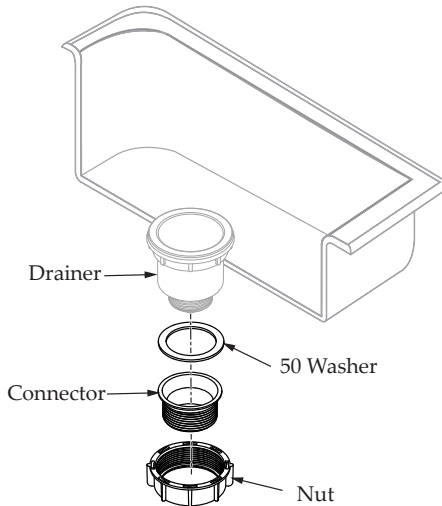

2. Slide the connector inside the nut. Place the 50 washer inside the connector and nut assembly and connect this to the strainer of the sink.

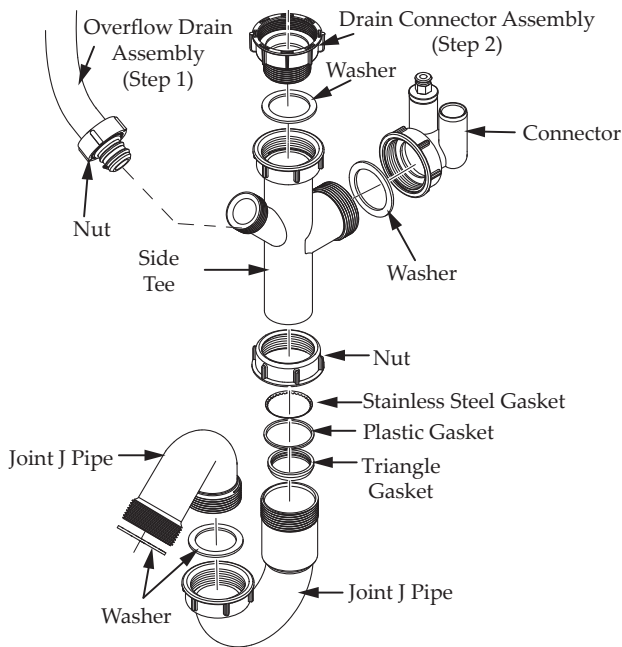

3. Connect the overflow drain assembly from step 1 to side tee with small nut. Connect the connector, side tee and both joint j pipes with nut, washer, nut, stainless steel gasket, plastic gasket, and triangle gasket located at each connection part. Connect this complete assembly of Step 3 to sink strainer assembly with washer and nut.

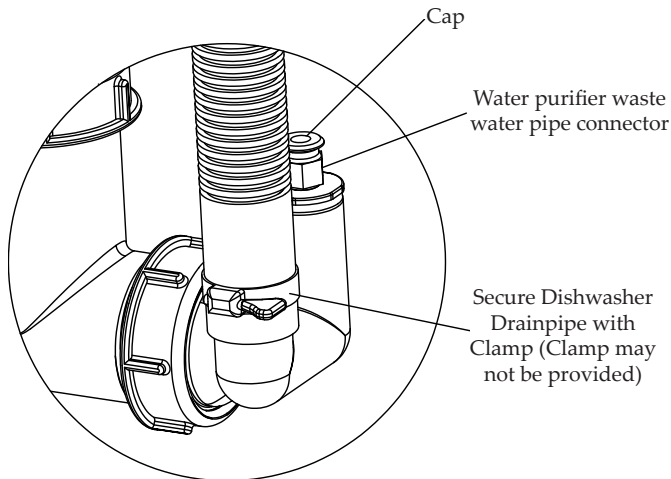

4. Connect the drain pipe of the dishwasher to the dishwasher drain pipe connector and lock the drain pipe with clamp (Clamp may not be provided). If necessary, remove the cap from the water purifier wastewater pipe connector and connect the purifier's wastewater pipe to the sink s-trap.

NOTE: To prevent the water leakage, do not open the cap if it is not necessary.

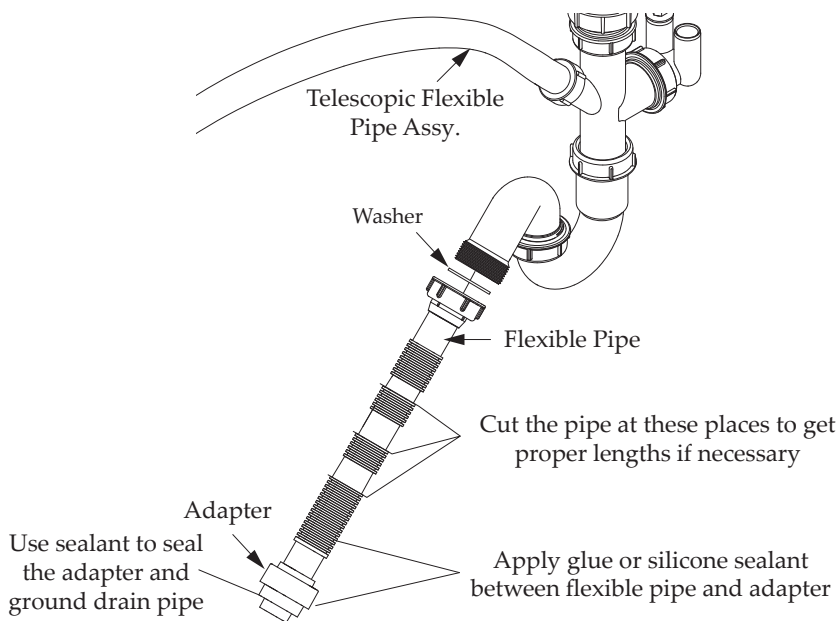

5. Connect Flexible Pipe to Joint J Pipe with washer and tighten the nut. Install the flexible pipe based on the actual distance between the sink and floor drain outlet. The telescopic flexible Pipe can be stretched or compressed to obtain the proper installation length.

NOTE: Verify that all gaskets are placed in correct directions and all the pipes are connected according to the assembly drawing. Tighten all the nuts only after all the pipes are properly connected.

Mainland China: +(86) 800 820 2628, +(86) 400 820 2628
www.kohler.com.cn

THE BOLD LOOK
OF **KOHLER**®

©2023 Kohler Co.



1520621-T2

1520621-T2-A